

# Cutting Tools

## Multi-Function SQUARE TYPE - 2 flutes

WC=90 Co=10 HV30 = 1571 Rupture=3750N/mm<sup>2</sup> Grain Size=0.6μm

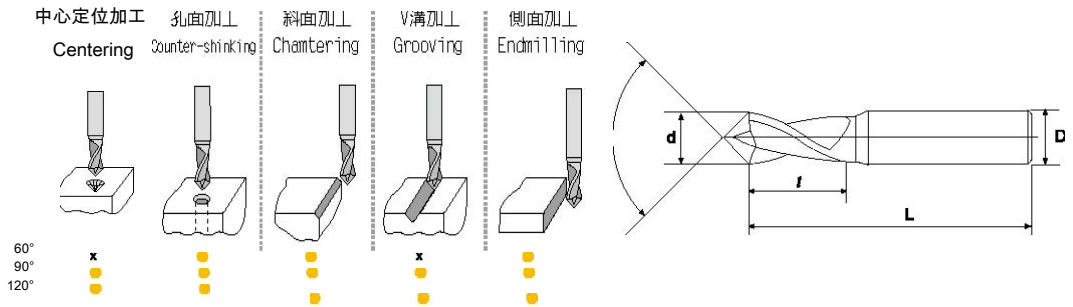

### MFM - Altin

MODE	Diameter d	Flute Length l	Full Length L	Shank Diameter D	Flute No. Z
MFM060030 - FTREME	3	6	50	4	60
MFM090030 - FTREME	3	6	50	4	90
MFM120030 - FTREME	3	6	50	4	120
MFM060040 - FTREME	4	8	50	6	60
MFM090040 - FTREME	4	8	50	6	90
MFM120040 - FTREME	4	8	50	6	120
MFM060050 - FTREME	5	10	50	6	60
MFM090050 - FTREME	5	10	50	6	90
MFM120050 - FTREME	5	10	50	6	120
MFM060060 - FTREME	6	12	60	8	60
MFM090060 - FTREME	6	12	60	8	90
MFM120060 - FTREME	6	12	60	8	120
MFM060080 - FTREME	8	16	75	10	60
MFM090080 - FTREME	8	16	75	10	90
MFM120080 - FTREME	8	16	75	10	120
MFM060100 - FTREME	10	20	75	12	60
MFM090100 - FTREME	10	20	75	12	90
MFM120100 - FTREME	10	20	75	12	120
MFM060120 - FTREME	12	25	75	12	60
MFM090120 - FTREME	12	25	75	12	90
MFM120120 - FTREME	12	25	75	12	120
MFM060140 - FTREME	14	28	80	14	60
MFM090140 - FTREME	14	28	80	14	90
MFM120140 - FTREME	14	28	80	14	120
MFM060160 - FTREME	16	32	100	16	60
MFM090160 - FTREME	16	32	100	16	90
MFM120160 - FTREME	16	32	100	16	120
MFM060200 - FTREME	20	35	100	20	60
MFM090200 - FTREME	20	35	100	20	90
MFM120200 - FTREME	20	35	100	20	120

